



Parts List

Frame	Foam Seal, Gas Strut Mounts and Striker Plates attached
Door Panel	Handles attached
Hinges	Assembled With face plates and strut mounts
Support Brackets	
10mm foam rubber	
Weather Strip	
Glue	310ml Sikaflex 291
Gas Struts	
Bag of bolts	4mm steel bolts, washers and Nylocs. 6mm nuts and washers Pan Head bolts
Instructions	

Tools Required

*Optional

Allen Keys	4mm and 2.5mm
Small Flat Bladed Screwdriver	
Philips screwdriver	
Clamps	
Spanners	7mm, 10mm and (27mm if removing handle)
Caulking/Glue Gun	
Rags	
*Chalk Pen	
Cleaning Fluid	To remove wax and grease from surfaces

The following instructions detail the installation of your new EmuWing kit; allow a total of one to two hours fitting time for each panel excluding curing time. Read the instructions thoroughly before starting.



1: Fixing the frame.

Before removing the existing rear window or interior trim; mark around the inside of the interior trim for later cutting. The gap at the bottom of the window between the glass and interior trim is adequate however this reduces at the sides and around the top. This will need to be trimmed before re-assembly.

Remove the interior trim and the plastic vent at the back of the window. Now the window can be removed, this is best done by a windscreen installer as it is attached using copious amounts of glue. After removing the rear window, wash off any dirt and cut away any residual glue from around the seam. If the body has been scratched in the removal process this would be the ideal time to use a little paint to prevent rust.

Fix the frame in place without glue; using clamps to hold it in place and assess where you will need to thicken the bead of Sikaflex to ensure no gaps between the body of the car and the frame.

Make sure you understand the positioning of the frame before attempting to glue it into position. This is critical so the panel aligns to the hinges later in the assembly. If you are not sure of the position we suggest a dry run first – Use a couple of bolts to fix the hinges to the frame and check the holes on the door panel align with the holes on the hinge face.

Remove the frame and apply a bead of Sikaflex around the inside edge of the window seam – approximately 5mm wide, ***paying particular attention*** to the corners increasing the bead enough to fill any higher spots between the body and the frame. Making sure there are no gaps in the bead.

Place the frame into position using the hole in the bottom left of the frame to align it to the plug hole left by the original window, The frame should be aligned with the top and bottom edges parallel to the body of the car ensuring the bolts at the top do not touch the edge of the panel of the vehicle.

Once the glue is applied and the frame is in place, apply clamps paying particular attention to the corners and leave to dry for at least 24 hours. Using a torch check no light can be seen between the frame and the car body.

You may also like to fill the centre of the plug left by the original window with a small amount of the supplied glue.

Whilst the glue is wet and the frame is clamped, carefully clean up any excess glue from around the frame. This can also be done when the Glue has set, with the careful use of a sharp knife.

Do Not proceed with fitting any hardware to the frame until the glue has set and the frame is securely in place (24 hours).



2: Attaching the door panel.

If you purchased panels powder coated the handles have been assembled and locktight has been applied. Otherwise: remove the door handles from the door panel. *When reassembling the handles use some locktite on the threads to prevent them loosening over time.*

Remove the nut, washer and spacer from the top of the frame. Put the support bracket in place. You can now measure the plastic spacer and file as necessary until it fits into the gap between the support bracket and the frame, (generally on this model the spacer is not required and can be discarded).

Assemble the support brackets on the top of the frame; using the previously removed parts to clamp the frame to the body. Do not over tighten these bolts.

Ensure the two bolts are evenly tightened so the slots in the two brackets align and the bracket is firmly against the body. You will need to roll the rubber back slightly to get the Allen key into the bolt, press firmly back in place.

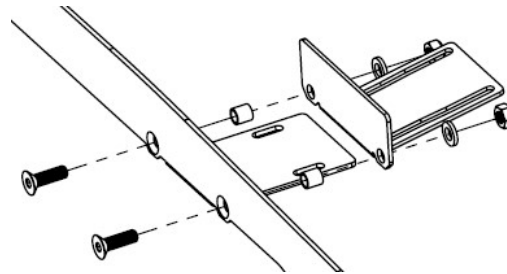

At this stage the interior trim can be cut and refitted, cutting is required around the edge that meets the frame; specifically at the top and tapering to nothing on the sides.

Some cutting will also be required at the top to allow for the support bracket and bolts – around 10 to 15mm should be sufficient but you should confirm this by aligning the panel and checking how much you need to remove.

Also at the top of the interior trim are two metal clips that clip into the roof – remove the metal clip and discard. Cut down the plastic tabs to allow clearance for the trim to fit over the support bracket and clip back into place.

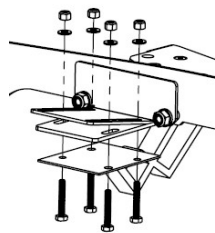

Attach the Hinges to the frame using the supplied 4mm nuts, bolts and washers so the face plate protrudes around 10mm from the frame. The exact depth will be adjusted later. Just tighten the two diagonally opposed bolts to one another for now. The hinges are marked for correct placement: PS – (Left) and DS – (Right).

Once the hinges are attached the plastic vent can be re-fitted on the outside rear of the window. Attach the 10mm foam rubber to the front inside edge of the vent from top to bottom following the existing channel. There may be a small piece of rubber on the vent put on by Nissan – this can be removed and discarded.

Once the foam rubber is in place refit the vent.



When the hinges are in the closed position, place the door panel centrally; we suggest using a spacer at the bottom of the door panel to lift it up slightly so that the panel is aligned correctly.

Note: when the gas struts are attached, the door panel will be pushed up 1mm to 2mm as the hinges compress – try to allow for this when placing the door.

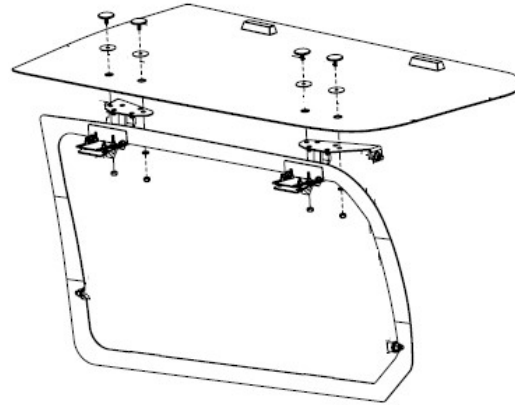

Close the handles a little so the cam latches over the frame to secure the panel in place while fixing into position. Placing the Pan Head bolts from the outside; fit a washer and nut on the inside (you may need some pressure on the outside of the panel to allow the nuts to catch onto the thread of the pan head) – If the threads still seem short, loosen the hinges and move them out.

Once all four pan heads are in place and secure, check that the door doesn't touch the car when opening and closing. If there is any touching, adjust the door accordingly before attaching the gas struts.

Once the Door panel is adjusted as much as possible screw in the rest of the bolts through the hinge into the support bracket – make sure everything is tight, open the door and attach the struts (wider end to the top). Close the panel carefully, again watching if it touches the car as it closes. Once closed note any required adjustments to the door panel to align it with the car. The depth of the door can be adjusted later, once the seal has been attached.

3: Adjusting the door panel and fitting the seal

Before loosening any nuts detach the gas struts.

The door panel can be adjusted up/down and left/right by releasing the pan heads that attach the door to the hinge. Make note of the required adjustments and mark the current position of the hinge plate on the inside of the door before removing the struts and loosening the pan heads.

Once you are happy the door panel is adjusted into position and the gas struts are reinstalled, the weather seal can be attached to the inside. Close the door panel and carefully mark inside the door panel around the inside edge of the frame noting the distance between the line and the edge of your frame - chalk pens are great for this.



Once the door has been marked, the weather seal can be attached to the door following outside of the marked lines so the seal will line up centrally with the foam rubber on the frame (if the seal does not align correctly moisture and dust will find its way into the back of the vehicle).

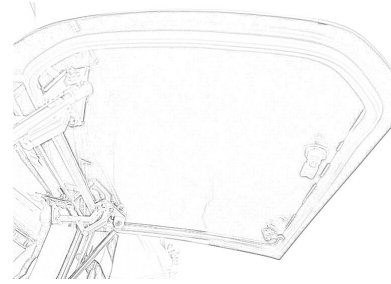

If you are unsure of how to place the weatherstrip in relation to your line, cut a small (10mm) section off the supplied rubber and test by attaching it to the door. Once the rubber is in place close the door for a few minutes, after this time when opening the door an indentation should be left on the foam rubber attached to the frame showing you how they are meeting when closed – if done correctly you will see and feel a clear indentation in the foam rubber on the frame left by the weatherstrip.

Once the weather seal has been set in place, close the door panel and check the depth to ensure it aligns with the car and compresses the rubber seal. If adjustment is required loosen the hinges from the top supports (the gas struts do not need to be removed), apply pressure evenly to the outside of the door where the hinge meets the door until you see the rubber compress, and then re-tighten the bolts.

You may also need to bend the cams on the door locks to compress the bottom part of the rubber seal, to do this remove the cam by taking the screw out from the back of the door handle. Put the cam into a vice so that any bend is applied away from the square hole – do not distort or bend this part of the cam. Bend slightly and then retest until the correct rubber compression is achieved – you should see a clear line where the weather seal pushes into the foam rubber on the frame. Close the EmuWing and leave the car in the sun for a few hours to activate the glue on the back of the weather seal – leave the wing closed for around 24 hours while the glue on the weather seal sets.

You will find some pieces of black tape in the kit cut to cover the holes left by removing the window, this will ensure you stay dry and dust free in the vehicle.

The interior panel will require some trimming around the support brackets at the top of the frame, as well as at the bottom to allow the door handle cams to close. Place the interior panel into position and mark where it will need to be cut.

If additional help is required, please feel free to give us a call on +613 90171614.